

PP 1 PTFE

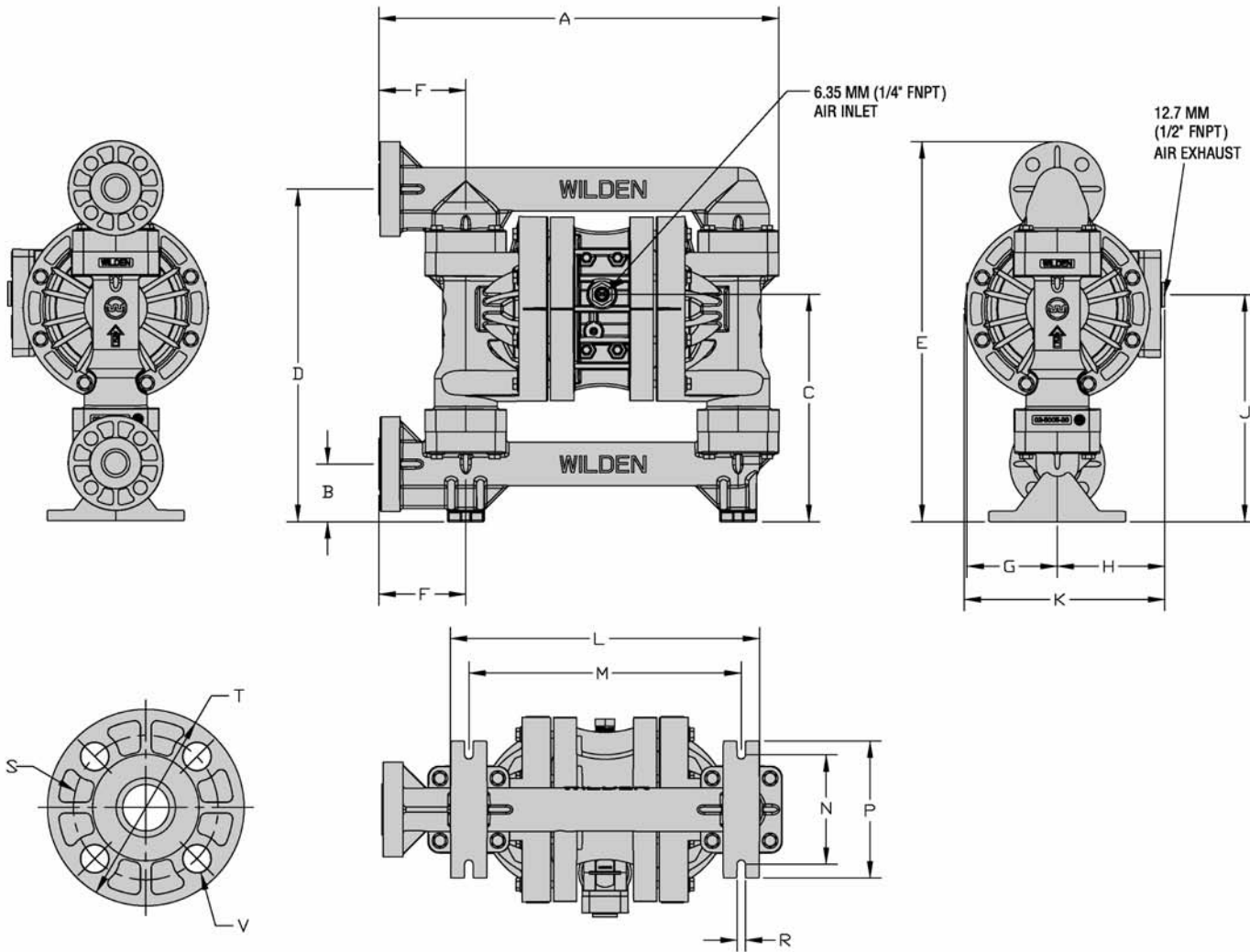

| DIMENSIONS – P200 ADVANCED™ PLASTIC | | |
|-------------------------------------|-------------|-----------------|
| ITEM | METRIC (mm) | STANDARD (inch) |
| A | 456.7 | 17.98 |
| B | 65.8 | 2.59 |
| C | 259.6 | 10.22 |
| D | 379.7 | 14.95 |
| E | 433.8 | 17.08 |
| F | 99.3 | 3.91 |
| G | 103.1 | 4.06 |
| H | 122.9 | 4.84 |
| J | 259.1 | 10.20 |
| K | 230.9 | 9.09 |
| L | 353.1 | 13.90 |
| M | 310.9 | 12.24 |
| N | 125.0 | 4.92 |
| P | 156.5 | 6.16 |
| R | 9.7 | 0.38 |
| | DIN (mm) | ANSI (inch) |
| S | 85.0 DIA. | 3.125 DIA. |
| T | 115.0 DIA. | 4.25 DIA. |
| U | 14.0 DIA. | .620 DIA. |

PP 1/2 PTFE

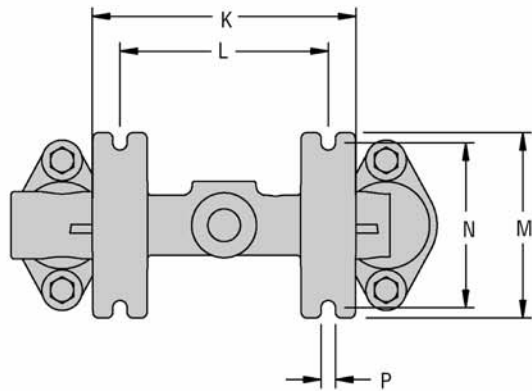
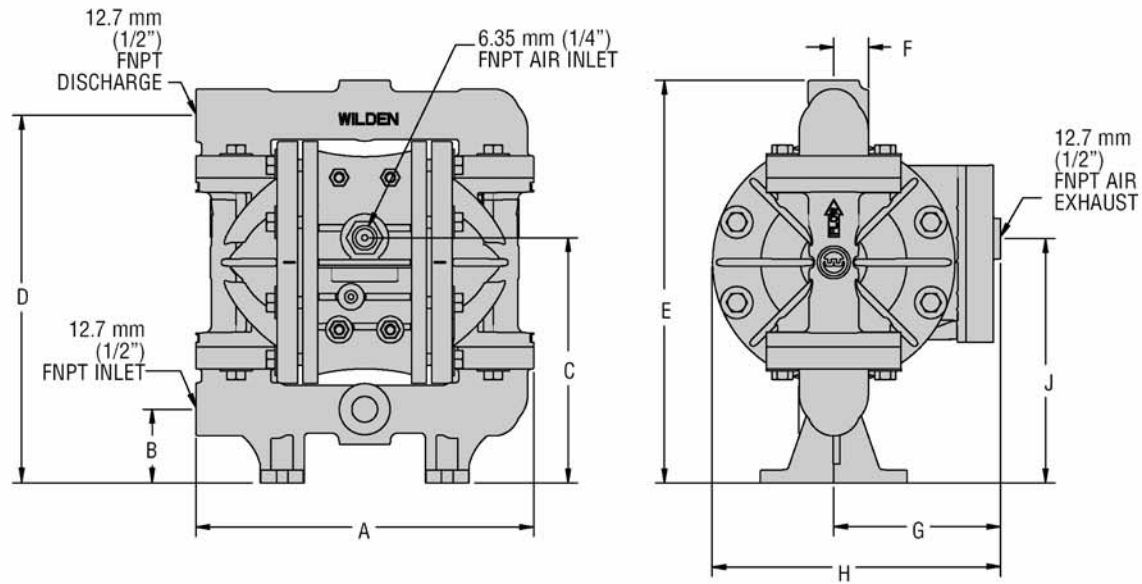

| DIMENSIONS - P100 ADVANCED™ PLASTIC | | |
|-------------------------------------|-------------|-----------------|
| ITEM | METRIC (mm) | STANDARD (inch) |
| A | 234 | 9.20 |
| B | 51 | 2.00 |
| C | 171 | 6.73 |
| D | 255 | 10.02 |
| E | 279 | 10.98 |
| F | 24 | 0.95 |
| G | 115 | 4.54 |
| H | 200 | 7.87 |
| J | 169 | 6.65 |
| K | 145 | 5.70 |
| L | 114 | 4.50 |
| M | 102 | 4.00 |
| N | 90 | 3.56 |
| P | 8 | 0.31 |

